



Quick Reference Notes – Daily Care

簡易操作 - 日常保養

Revoria Press SC180

CONTENTS

目錄

1	Clear Paper Jam 夾紙排解	1
1.1	Duplex Automatic Document Feeder / 自動雙面送稿裝置	1
1.2	Inside Lower Left Cover 左下蓋內部	3
1.3	Right Side 右側面部	3
2	Trays 紙盤	4
2.1	Paper Trays 1, 2 & 3 紙盤 1, 2 & 3	4
2.2	Bypass Tray (Tray 5) 手送紙盤 (紙盤 5)	5
3	Transfer Units 轉印元件	6
4	Replacing Toner 更換碳粉匣	9
4.1	Confirm the status of supplies 確認耗材狀態	9

Scan QR Code OR Click here for more instruction.

請掃描 QR Code 或者點擊這裡查看更多使用說明。

For more online support information please visit

更多相關資料，請訪問以下網址：

<https://support-fb.fujifilm.com>



1 CLEAR PAPER JAM 夾紙排解

1.1 DUPLEX AUTOMATIC DOCUMENT FEEDER / 自動雙面送稿裝置

1. Pull up the front handle of the cover and open the cover until it stops.

1. 提起護蓋前的把手，開啟護蓋直到停止位置。

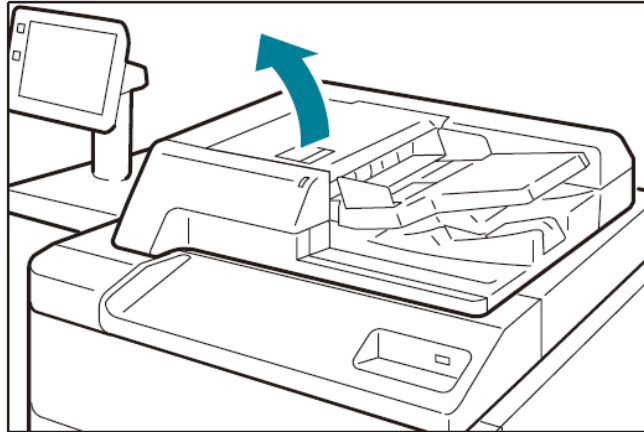

2. Remove the document.

2. 清除原稿。

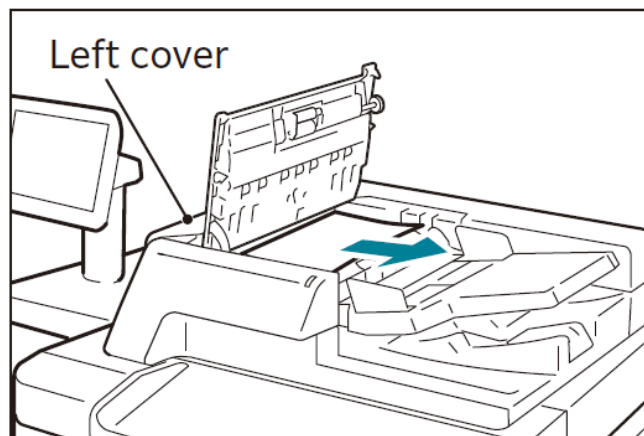

3. If the document is caught in the entry, remove the jammed paper from the Left Cover.

3. 原稿夾在吸入部時，可從左側蓋子進去清除原稿。

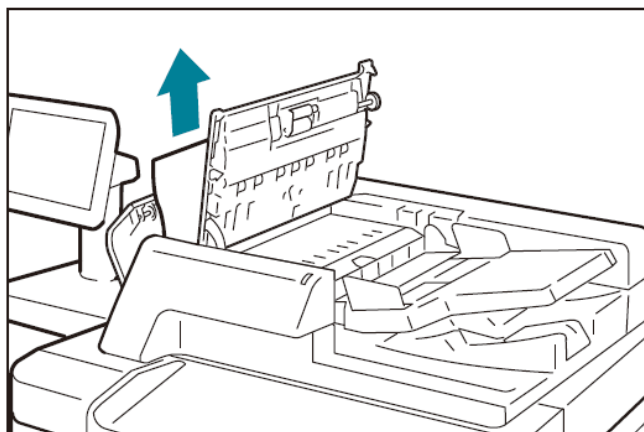

4. If the document is caught in the exit area, lift the Document Feeder Tray and pull the document toward the exit.
4. 輸出口有原稿時，請提起送稿台，朝輸出方向拉取出來。

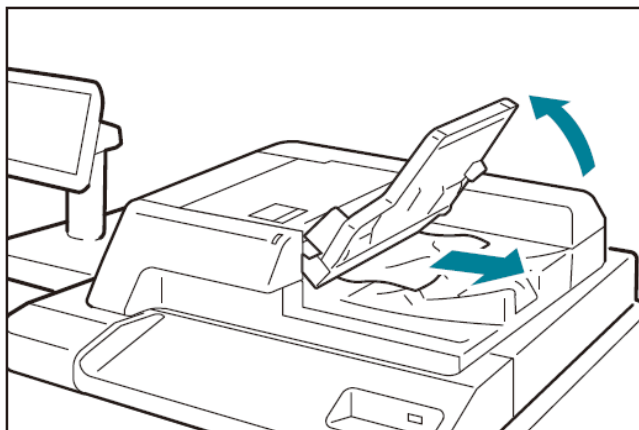

5. Open the Document Cover, pull down the handle to open the Side 2 scanner, and then remove the document.
5. 打開原稿蓋，拉下拉桿，開啟反面掃描部，取出原稿。

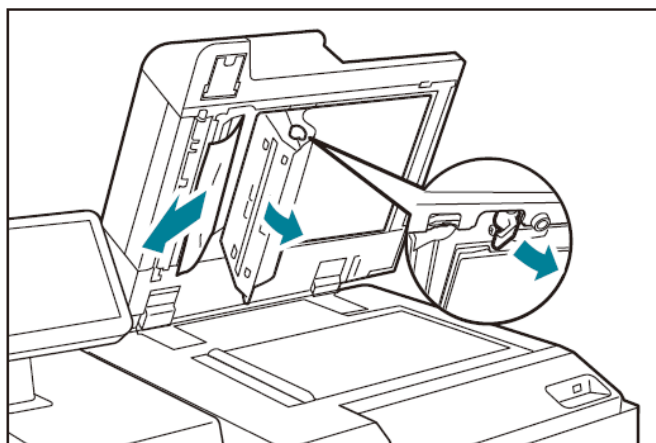

1.2 INSIDE LOWER LEFT COVER 左下蓋內部

1. Open the Lower Left Cover.
2. Remove the jammed paper.

1. 打開左下蓋。
2. 清除卡住的紙張。

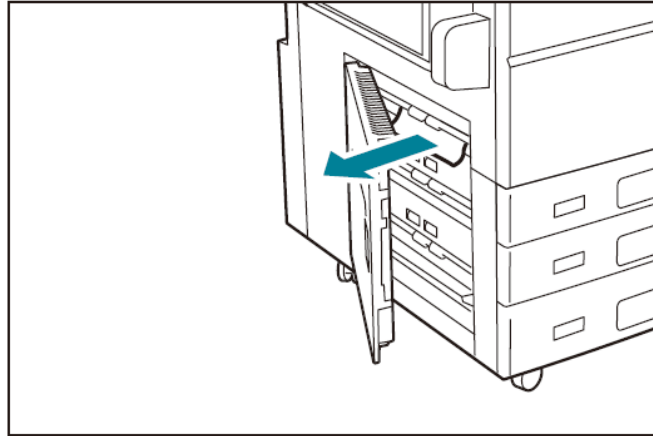

1.3 RIGHT SIDE 右側面部

1. Open the Lower Right Cover.
2. Remove the jammed paper.

1. 打開右下蓋。
2. 清除卡住的紙張。

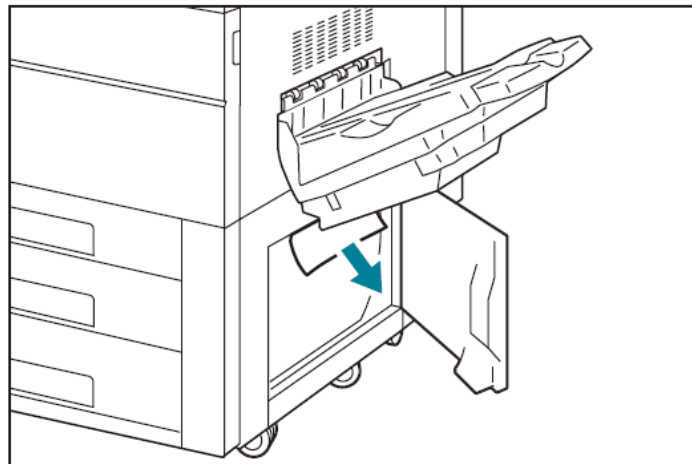

2 TRAYS 紙盤

2.1 PAPER TRAYS 1, 2 & 3 紙盤 1, 2 & 3

1. Pull out the Paper Tray where the paper jam occurred until it stops.

1. 將發生卡紙的紙盤完全拉出。

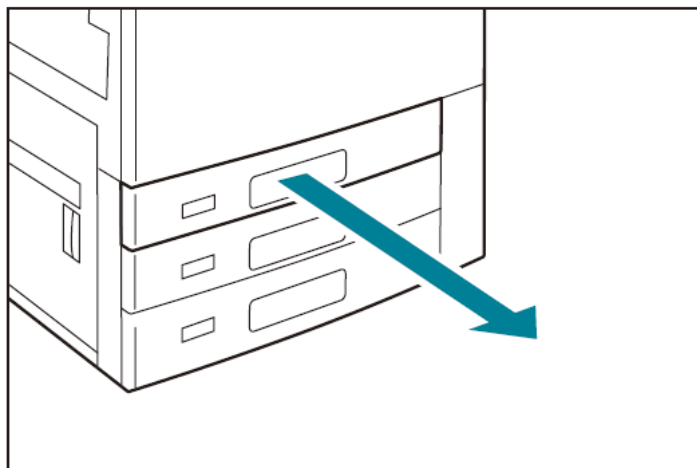

2. Remove the jammed paper.

2. 清除卡住的紙張。

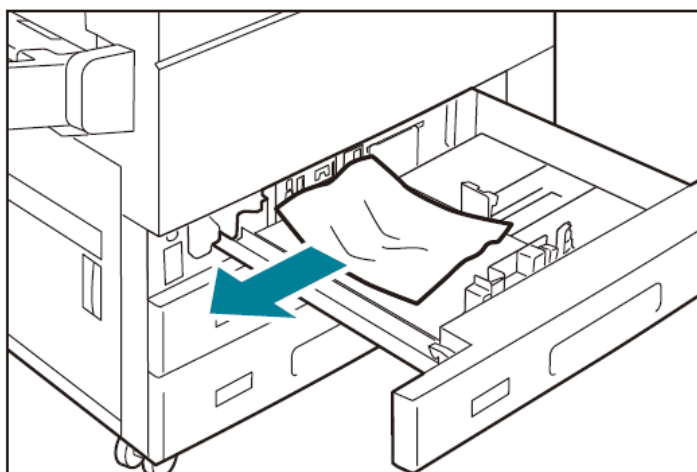

2.2 BYPASS TRAY (TRAY 5) 手送紙盤 (紙盤 5)

1. Remove the jammed paper.

1. 清除卡住的紙張。

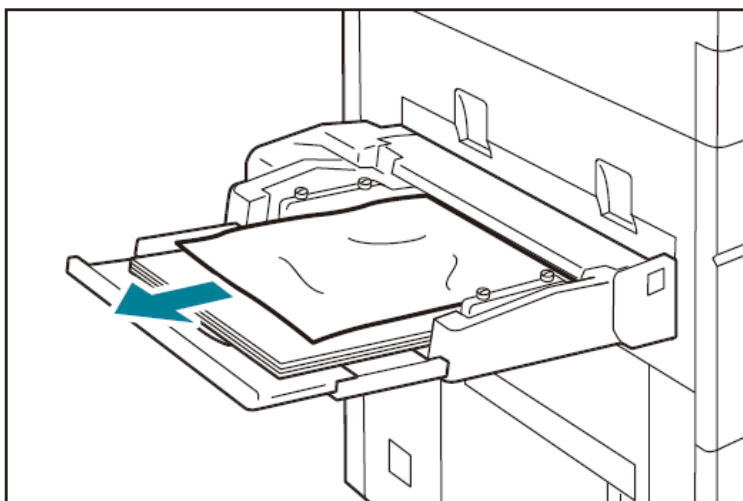

3 TRANSFER UNITS 轉印元件

1. Open the Front Cover.

1. 打開前蓋。

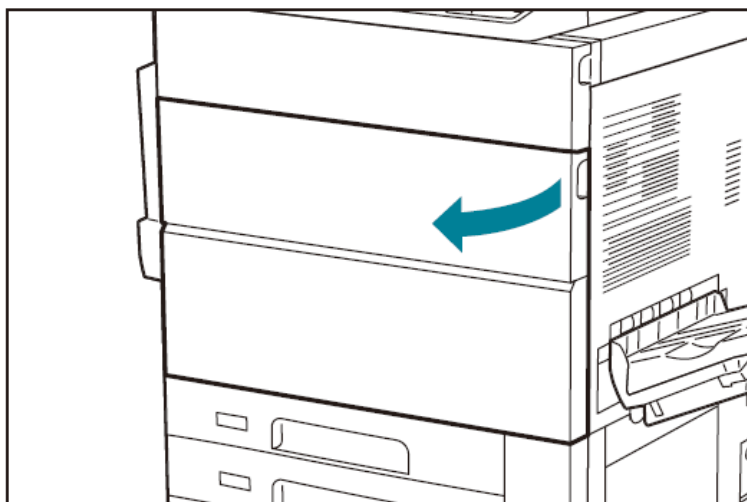

2. Turn the handle [2] of the Transfer Unit to the right until it becomes horizontal (①) and pull the Transfer Unit out to the front until it stops (②).

2. 將轉印元件的拉桿 [2] 往右旋轉直到呈水平為止(①)，再將轉印元件往前方拉開到停止位置(②)。

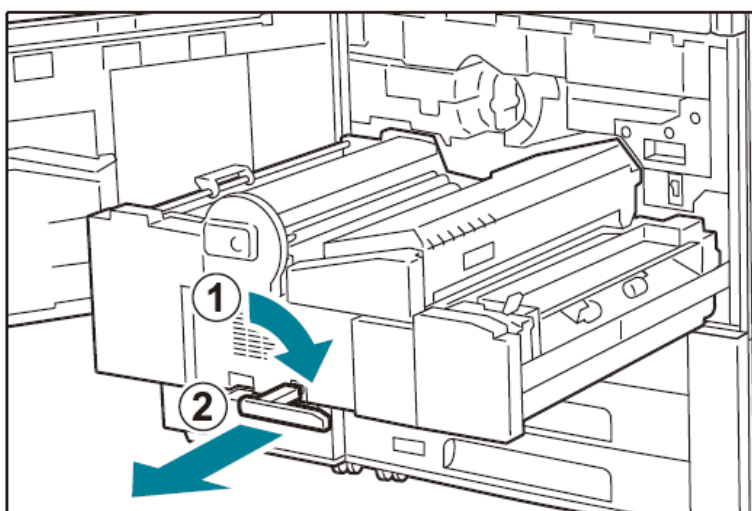

3. Remove the jammed paper at [2a]. Move the handle [2b] to the right and remove the jammed paper.

3. 清除 [2a] 卡住的紙張。向右拉開 [2b] 拉桿，清除卡住的紙張。

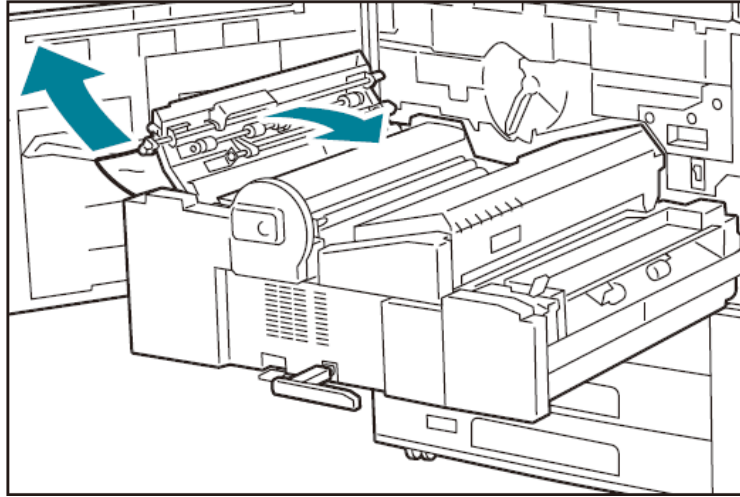

4. Remove the jammed paper at [2c].

5. 清除 [2c] 卡住的紙張。

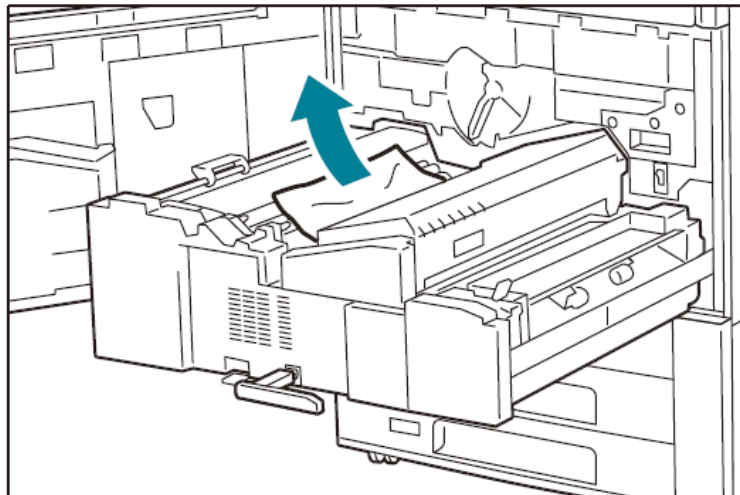

5. Lift up the handle [2d] (①) and move the handle [2e] to the right (②), then remove the jammed paper (③).

5. 提起拉桿 [2d] (①)，然後向右拉開拉桿 [2e] (②)，清除卡住的紙張 (③)。

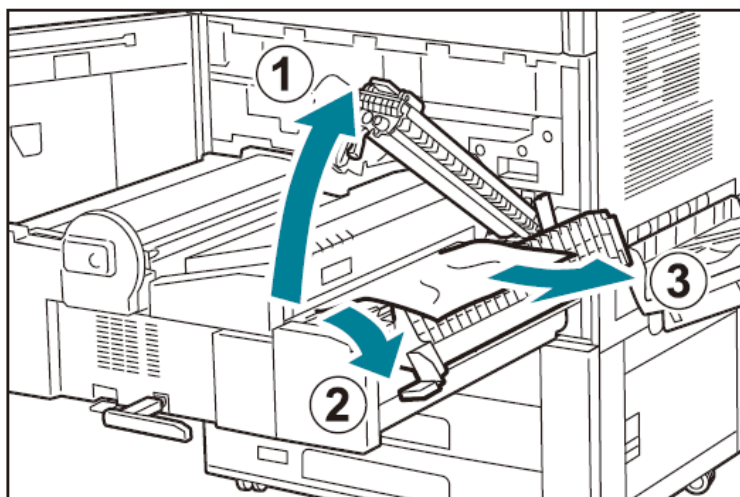

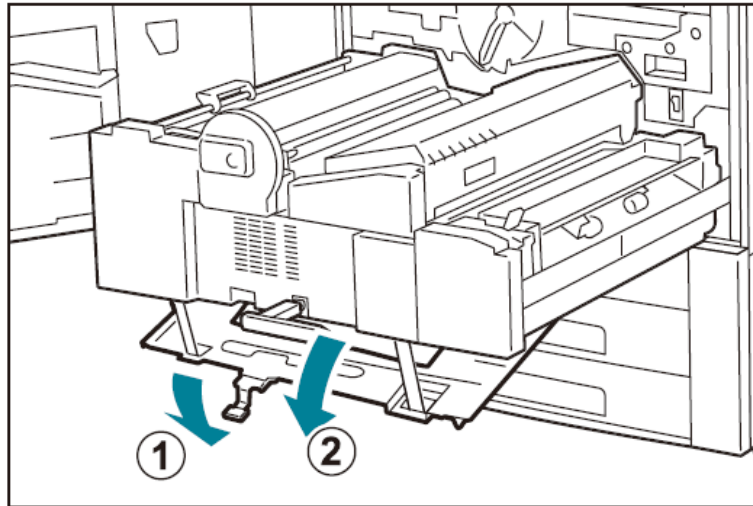

6. Move the handle [2f] down and remove the jammed paper.

6. 拉下拉桿 [2f]，清除卡住的紙張。



4 REPLACING TONER 更換碳粉匣

4.1 CONFIRM THE STATUS OF SUPPLIES 確認耗材狀態

1. To display the consumables progress, tap on  .
1. 若要顯示各耗材的狀況，請點選  。

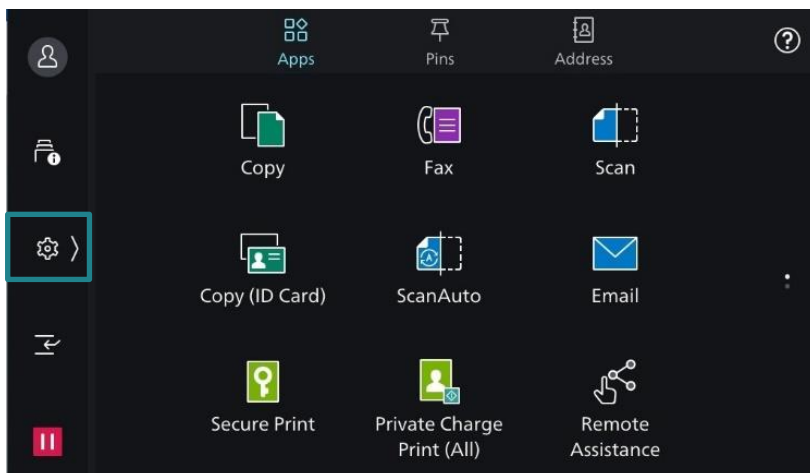

2. Tap on [Device Status].
2. 點選【機器確認(計量確認)】。

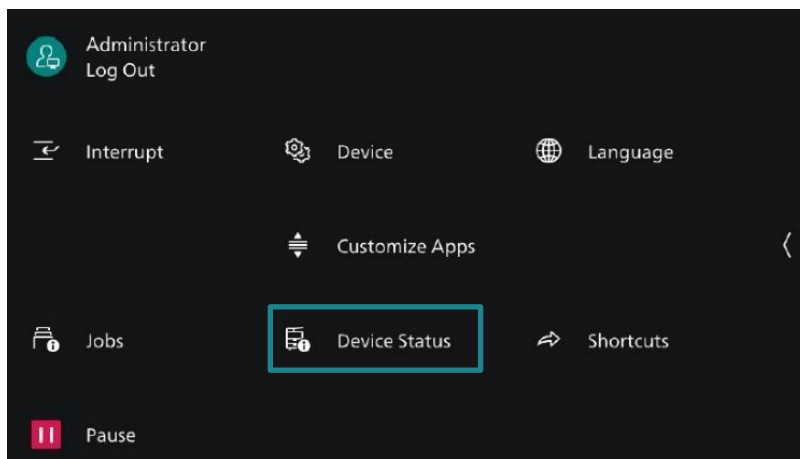

3. Tap on [Supplies].
3. 點選【耗材確認】。

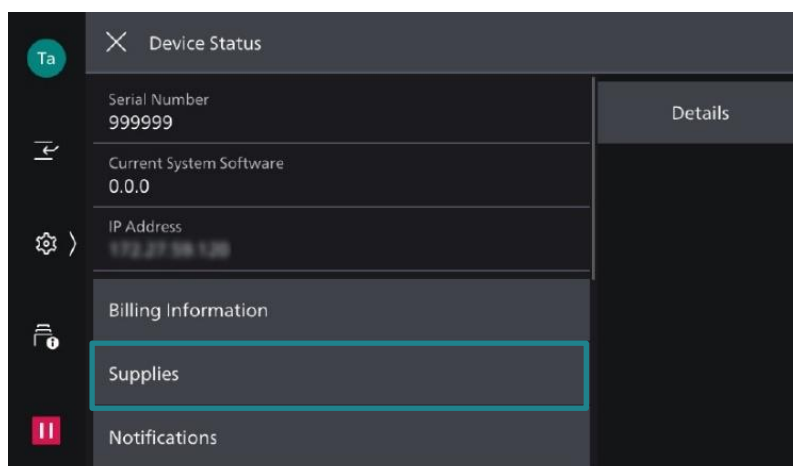

4. For the replacement method, refer to the steps provided on the box of the consumable.

4. 更換的方法請參考耗材外盒上所記載的步驟。

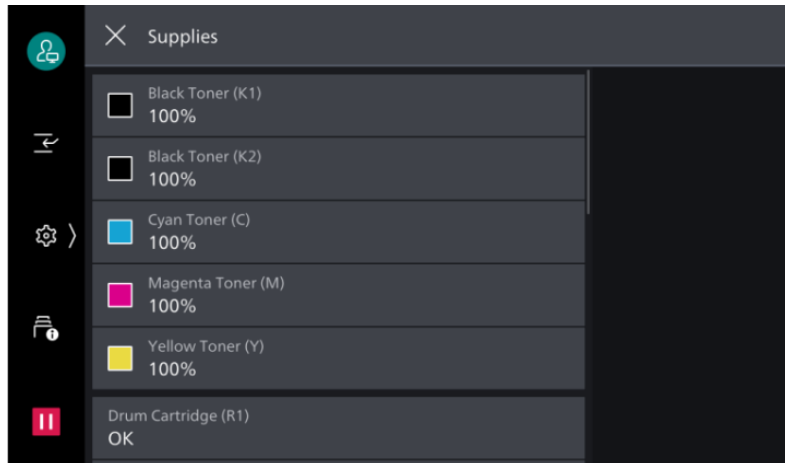

Customer Support Center

2513-2513